



Didistribusikan oleh:
PT Honda Power Product Indonesia
Jl. Iskandar Muda No 97
Jakarta-12240, Indonesia
Tel : 021-7294450/58
Fax : 021-7294452/56
Web site : www.hondapowerproducts.co.id
E-mail : cs@hppi.co.id



4MYG0610
00X4M-YG0-6100

© Honda Motor Co., Ltd. 2012
DICETAK DI INDONESIA

-1-

KESELAMATAN

JANGAN DIGUNAKAN DIDALAM RUMAH

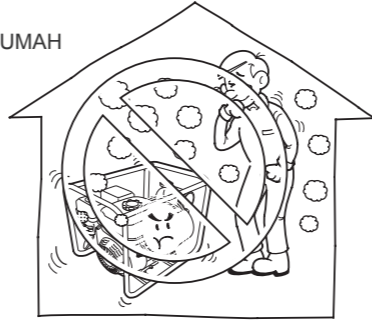

JAUHKAN DARI BAHAN MUDAH TERBAKAR

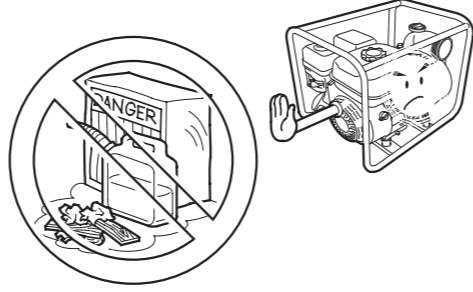

-2-

Ketika mengisi:

HENTIKAN MESIN

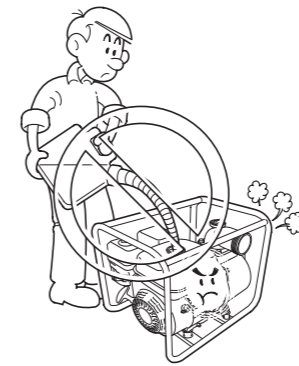

JANGAN TUMPAH!

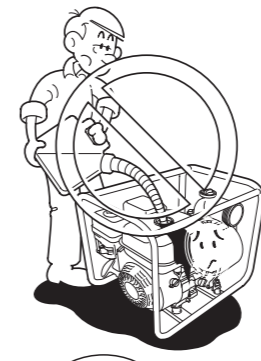

DILARANG MEROKOK!



-3-

PEMERIKSAAN SEBELUM PENGOPERASIAN

1. KAPASITAS OLI MESIN

Peringatan:
Periksa kapasitas oli dengan pompa dikondisi permukaan yang rata dan mesin berhenti.

Honda Power Oil
MOTOR 4 LANGKAH
SAE 10W-30
API SJ atau di atasnya



-4-

1. Periksa kapasitas oli dikondisi permukaan yang rata.



2. Jika kapasitas oli rendah, tambahkan oli sampai mencapai sisi terluar dari lubang pengisi oli.

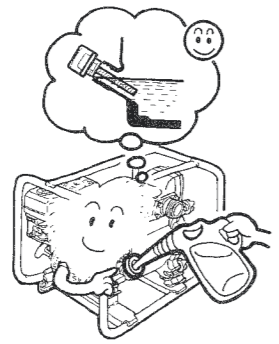

-5-

2. KAPASITAS BAHAN BAKAR

1. Periksa tangki bahan bakar dengan membuka tutup tangki bahan bakar.

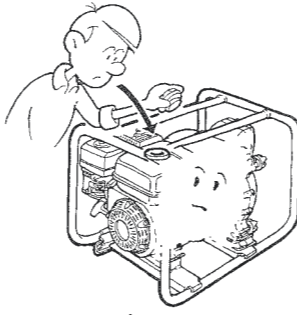

2. Jika kapasitas bahan bakar rendah, isi bahan bakar sampai batas atas c.

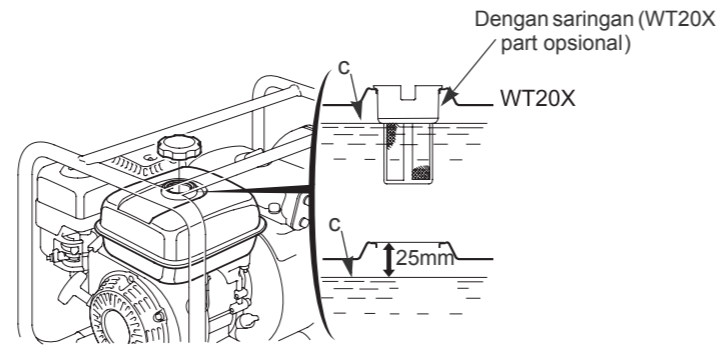

-6-

Jangan pernah menggunakan campuran oli/bensin atau bensin kotor

KAPASITAS TANGKI BAHAN BAKAR:
WT20X: 3.1 L
WT30X: 5.3 L
WT40X: 6.1 L

-7-

3. FILTER UDARA

1. Lepaskan mur sayap dan tutup filter udara.

2. Periksa elemen filter udara dari kotoran. Jika elemen kotor, bersihkan (P.22)

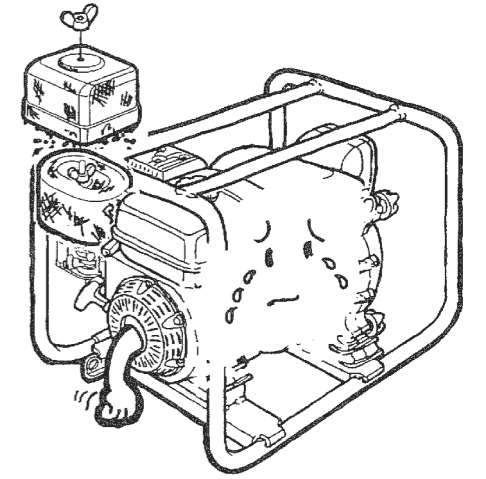

-8-

PERSIAPAN

1. Hubungkan selang hisap dan selang buang .

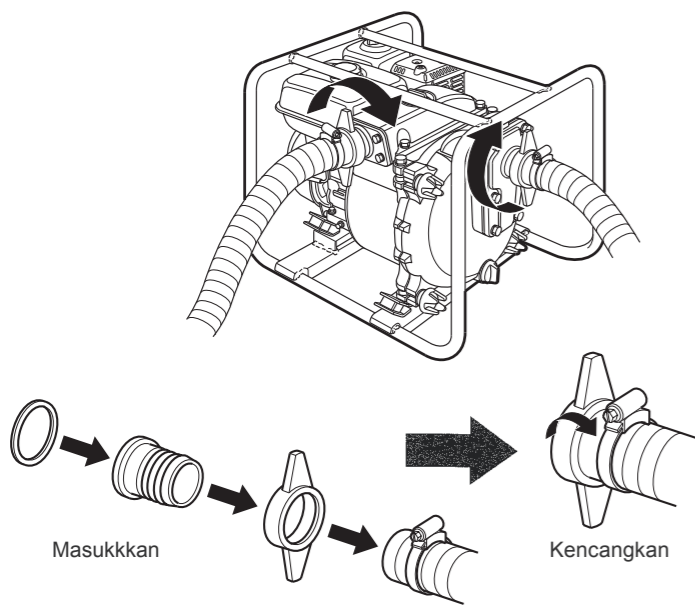

-9-

2. Pasang penyaring diujung selang hisap.

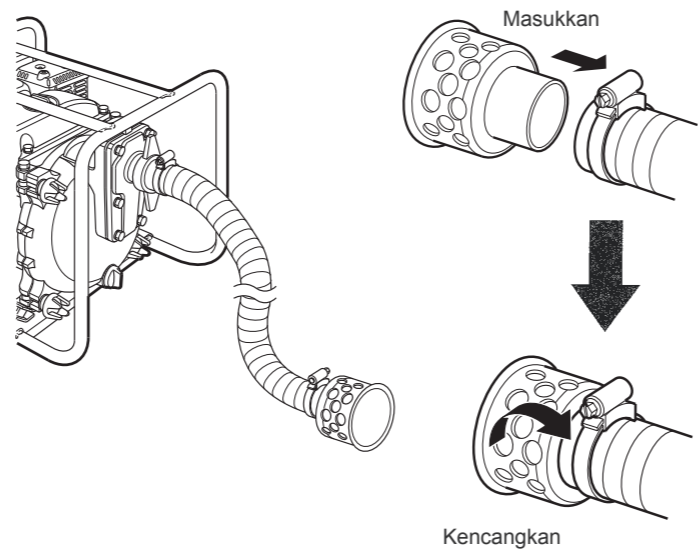

-10-

3. Isi air pemancingan di ruang pompa.

KAPASITAS AIR PEMANCINGAN:
WT20X: 14 L
WT30X: 15 L
WT40X: 15 L

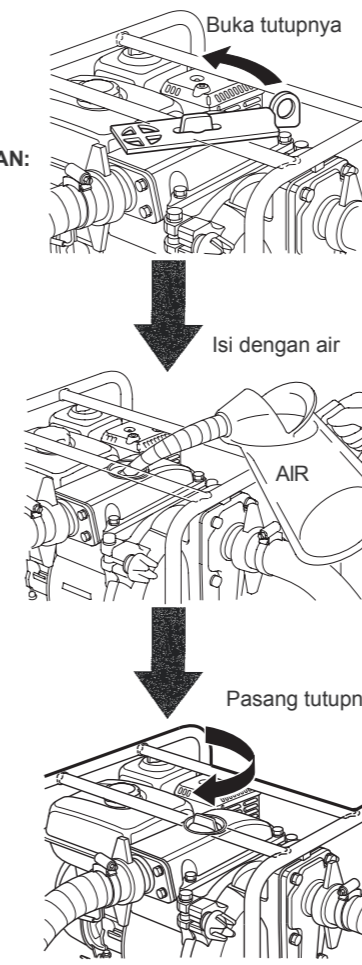

-11-

MENGHIDUPKAN MESIN

1. Putar tuas bahan bakar ke posisi ON.

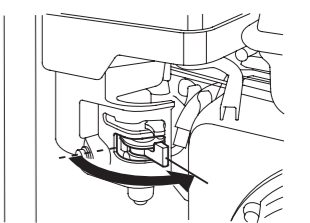

2. Putar tuas choke ke posisi TUTUP.

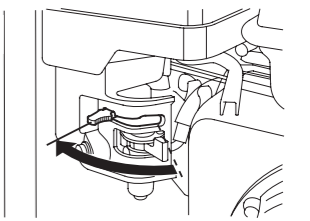

3. Putar saklar mesin ke posisi ON.

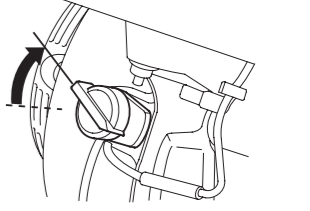

-12-

4. Pindahkan tuas gas sedikit ke arah kiri.

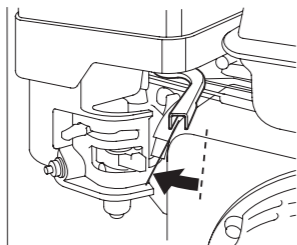

5. Tarik pegangan rekoil starter dengan pelan sampai anda merasakan tertahan, kemudian tarik dengan cepat.

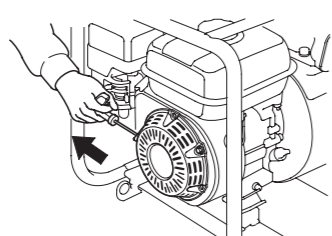

PERINGATAN:

Jangan biarkan pegangan rekoil starter langsung kembali ke mesin. Kembalikan secara perlahan untuk mencegah kerusakan rekoil starter.

-13-

6. Memanaskan mesin. Secara bertahap buka chokenya

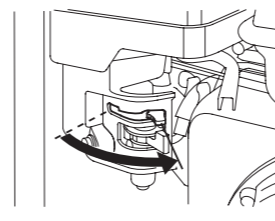

7. Posisikan tuas gas dikecepatan yang didinginkan

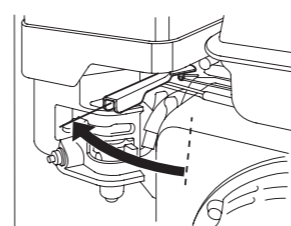

Sistem peringatan oli (Tipe yang tersedia)
Sebelum ketinggian oli di crankcase berada dibatas aman, maka sistem peringatan oli akan secara otomatis menghentikan mesin. (saklar mesin akan diingatkan di posisi ON).

-14-

MENGHENTIKAN MESIN

1. Pindahkan tuas gas penuh ke kanan.

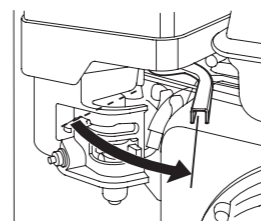

2. Putar saklar mesin ke posisi OFF.

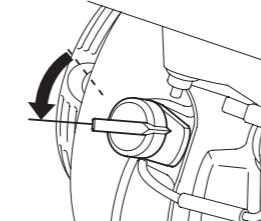

3. Putar tuas katub bahan bakar ke posisi ON.

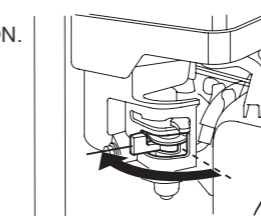

-15-

SETELAH DIGUNAKAN

1. Lepaskan tutup pembuangan (c) dan buang airnya.

2. Longgarkan tutup knob (d) dan buka tutup pompa (e) dan bersihkan bagian dalam pompa dan volute case nya.

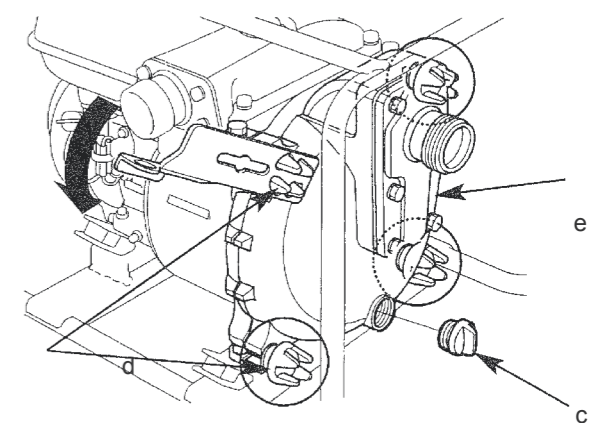

-16-

- Pasang volute case (f) dan O-ring (g) ditutup pompa dengan berhati-hati supaya tidak merusaknya.

- Pasang tutup pompa (e) dan kencangkan tutup knop (d). Pasang tutup pembuangan

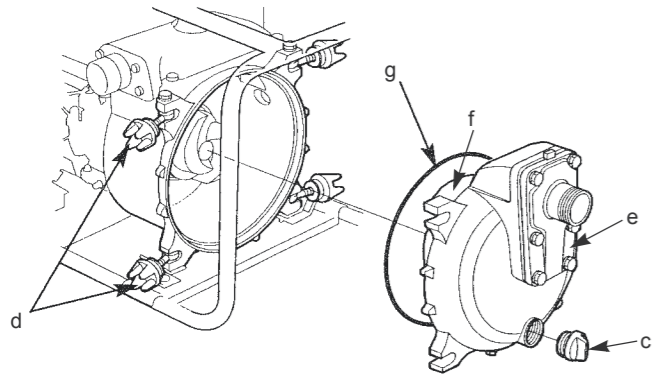

-17-

PERAWATAN

JADWAL PERAWATAN

	Periksa	Ganti	Bersihkan
Periksa-setel			
Ganti jika perlu			

Item	Pertama	50	100	300